



IDA – SCA

Self – Contained Air Cooled
Multi Deck Full Height Medium
Temperature
Floral Cabinet



Multi Deck Full Height - Floral Cabinet

Cabinet Type: Self – Contained Air Cooled

Model Designation: **IDA - SCA**

Contents:

- Section 01.** Cabinet Technical Data
- Section 02.** Cabinet Side View
- Section 03.** Cabinet Plan View Showing Drain & Foot Locations
- Section 04.** Cabinet Plan View Showing Cabinet Layout Into Corner
- Section 05.** Cabinet Plan View Showing Condensing Unit & Electrical Control Panel Location

- Section 06.** Electrical Schematic Control Panel details
- Section 07.** Electrical Wiring EVAP Fan Assembly
- Section 08.** Electrical Wiring LHS Condensing Loom
- Section 09.** Dixell Display Assembly Connections To Electrical Control Panel
- Section 10.** Kick Plate Assembly Connections To Electrical Control Panel

- Section 11.** Condensate Pan Heater
- Section 12.** Air 'Return' & 'Discharge' Probe Locations

Document Issue:

- | | |
|----------------------------------|------------------------------|
| (1) July 29 th 2020 | DR – 1 st Release |
| (2) June 14 th 2022 | IP – 2 nd Release |
| (3) June 28 th 2022 | IP – 3 rd Release |
| (4) July 28 th 2022 | IP – 4 th Release |
| (5) August 23 rd 2022 | IP – 5 th Release |
| (6) April 05 th 2023 | IP – 6 th Release |
| (7) April 20 th 2023 | BK – 7 th Release |

Section 01. Cabinet Technical Data Sheet: IDA – SCA - TXV

Product Type

Floral Cabinet

Maximum Design Ambient

75°F @ 55% RH

Case Length

12' (3 x 4ft)	8' (2 x 4ft)	6'	4'
--------------------------------	-------------------------------	-----------	-----------

Refrigeration Data

Refrigerant Charge per System (R449A)	1644 grams 58 oz 3lb 10 oz	1644 grams 58 oz 3 lb 10 oz	1843 grams 65 oz 4 lb 1 oz	1644 grams 58 oz 3 lb 10 oz
---------------------------------------	----------------------------------	-----------------------------------	----------------------------------	-----------------------------------

No. of Systems per Cabinet	3	2	1	1
----------------------------	---	---	---	---

TXV Orifice size	01	01	01	01
------------------	----	----	----	----

**Electrical Data (115v 60 Hz)
(Hot , Neutral & Ground)**

Amps	Amps	Amps	Amps
-------------	-------------	-------------	-------------

Evaporator Fan Motors	0.42	0.28	0.21	0.14
Condenser Fan Motors	2.43	1.62	1.08	0.81
Lights (LED): Canopy only	0.6	0.4	0.3	0.2
Controller	0.24	0.16	0.08	0.08
Kick Plate Fans	0.12	0.8	0.45	0.4
Re-evaporator tray	6.6 (x3)	6.6 (x2)	0	6.6

Electrical Data (208v 60 Hz)(2 Hots & Ground)

Amps	Amps	Amps	Amps
-------------	-------------	-------------	-------------

Re-evaporator tray	0	0	7.7	0
Condensing Unit	6.5 (x3)	6.5 (x2)	8.8	6.5
Single Point Load (MCA – Ref Based on UL Calculations)	15.8 (x3)	15.8 (x2)	19.9	15.8
MOPD (Based on UL Calculations)	20 (x3)	20 (x2)	25	20

Miscellaneous Data

Total Heat Rejection (THR) (BTU/hr)	33810	22540	16,905	11,270
Evaporator Case Load (THR) (BTU/hr) (10°F)	14214	9476	7107	4738
Total Internal Volume Cu.ft	110	74	55	37
Condensate Volume (Gallons/ 24hours)	18	12	8.5	6

Drainage Connection Right Hand Side of Each Section

Electrical Connection Via Electrical Distribution Board

Section 01. Cabinet Technical Data Sheet: IDA – SCA – continued

Case Length	12'	8'	6'	4'
Fan Speed				
Evaporator: Run State (RPM)	1350	1350	1350	1350
Evaporator: Defrost (RPM)	1350	1350	1350	1350
Condenser: (ECF/UNADA RPM)	1650/1550	1650/1550	1650/1550	1650/1550
Compressor				
	Hitachi	Hitachi	Hitachi	Hitachi
Make & model	ZS7516X1 (1.0 H.P) x3	ZS7516X1 (1.0 H.P) x2	ZS1120X1 (1.5 H.P) x1	ZS7516X1 (1.0 H.P) x1
Start Capacitor Size (per compressor box)	40µF / 450V	40µF / 450V	40µF / 450V	40µF / 450V
Run Capacitor Size (per compressor box)	30µf/ 450v	30µf / 450v	30µF / 450V	30µF / 450V
Pressure Switch				
		HP	LP	
Open (PSI)		410	3	
Close (PSI)		310	15	
Temperature Sensor				
Make & Model	CPC 10k			
Typical Air Flow At Honeycomb				
Air Flow (Cu.Ft /min)	1695			
Set – Up Data				
	Floral			
Set Point Temperature (F°)	48			
Differential (F°)	8			
Evaporating Temperature - Calculated (F°)	35			
Cabinet Temperature Ratio (air return / discharge %)	100			
Anti – Cycle Time (seconds) (compressor between starts)	180			
No. Defrosts (per 24hrs)	6			
Maximum Defrost Time (minutes)	45			
Defrost Termination Temperature (air discharge) (F°)	50			
Cabinet Off Time After Defrost (mins) (drain down)	1			
Fans in Defrost	ON			

Section 02. Cabinet Side View Drawing IDA - SCA

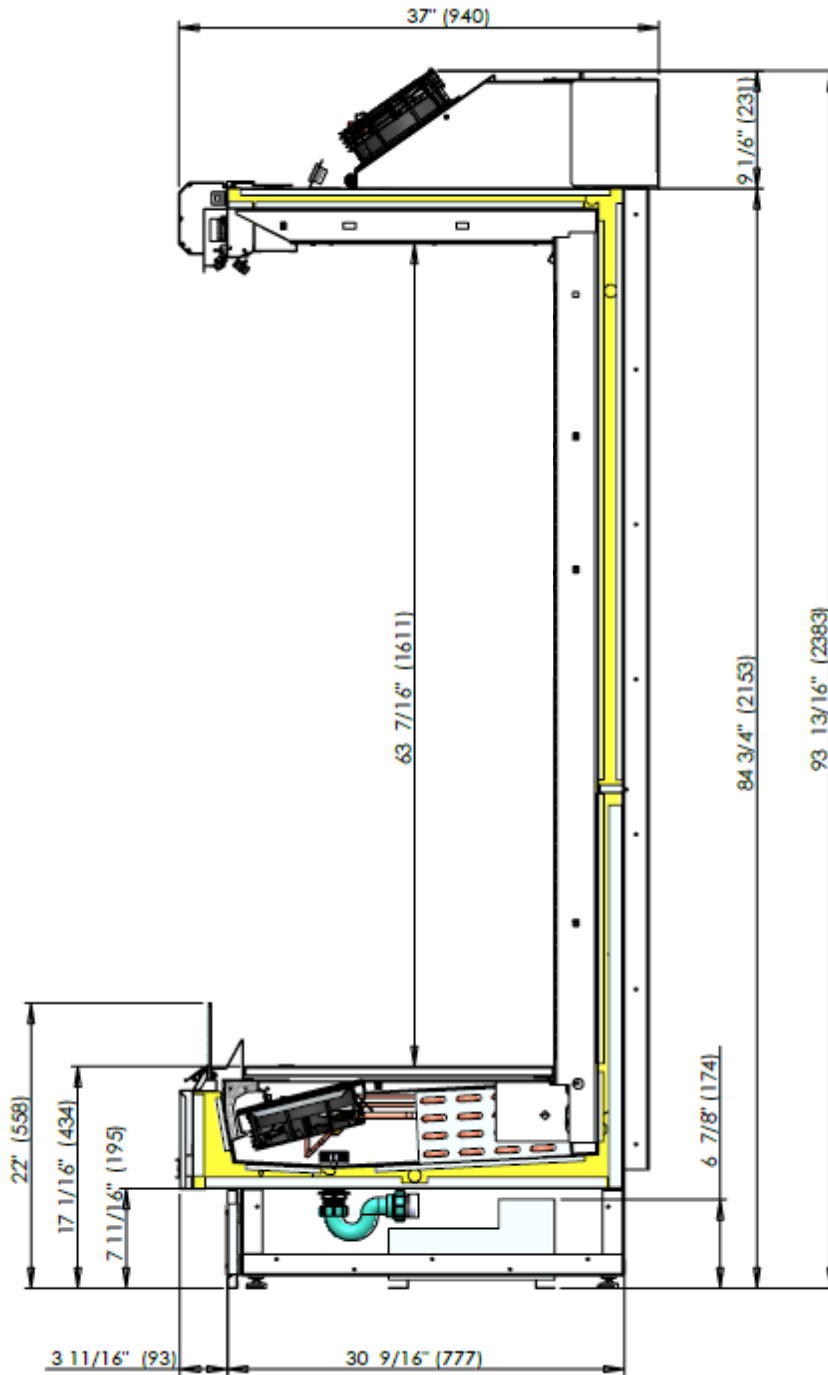

**Drawing Measurements
Inches (Metric Millimetres)**

Section 03. Cabinet Base Plan Showing Drain, Cond. Pan & Foot Locations IDA - SCA

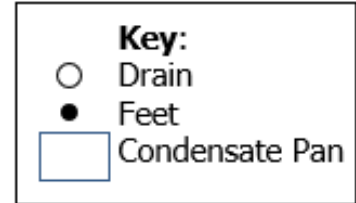
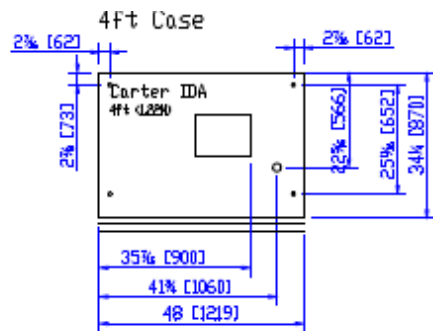

Drawing Measurements
Inches (Metric Millimetres)

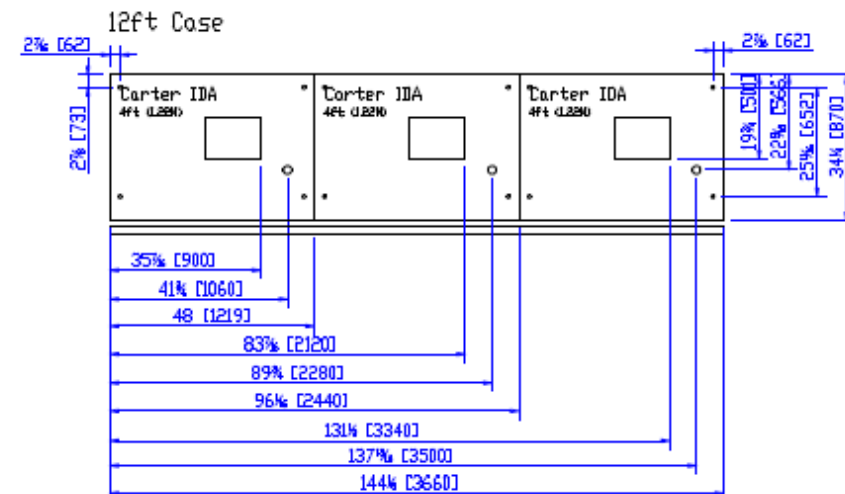
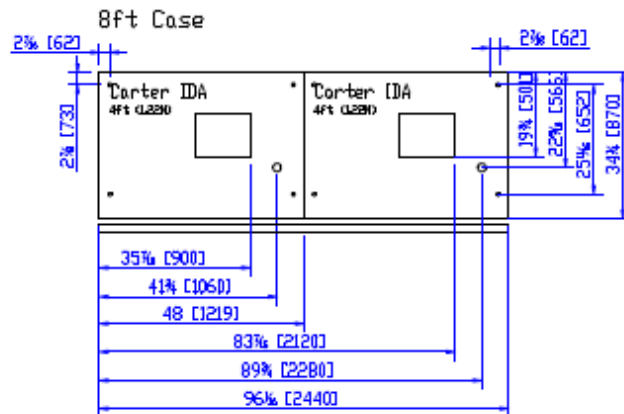
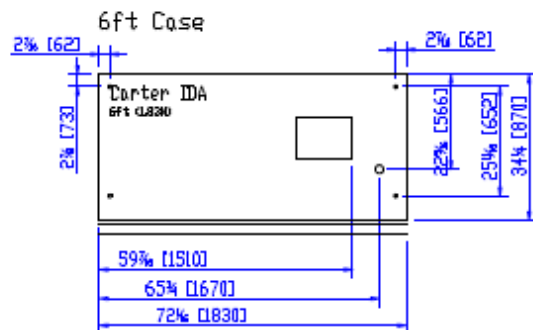

**Section 04. Cabinet Plan View Showing Cabinet Layout Into Corner
IDA - SCA**

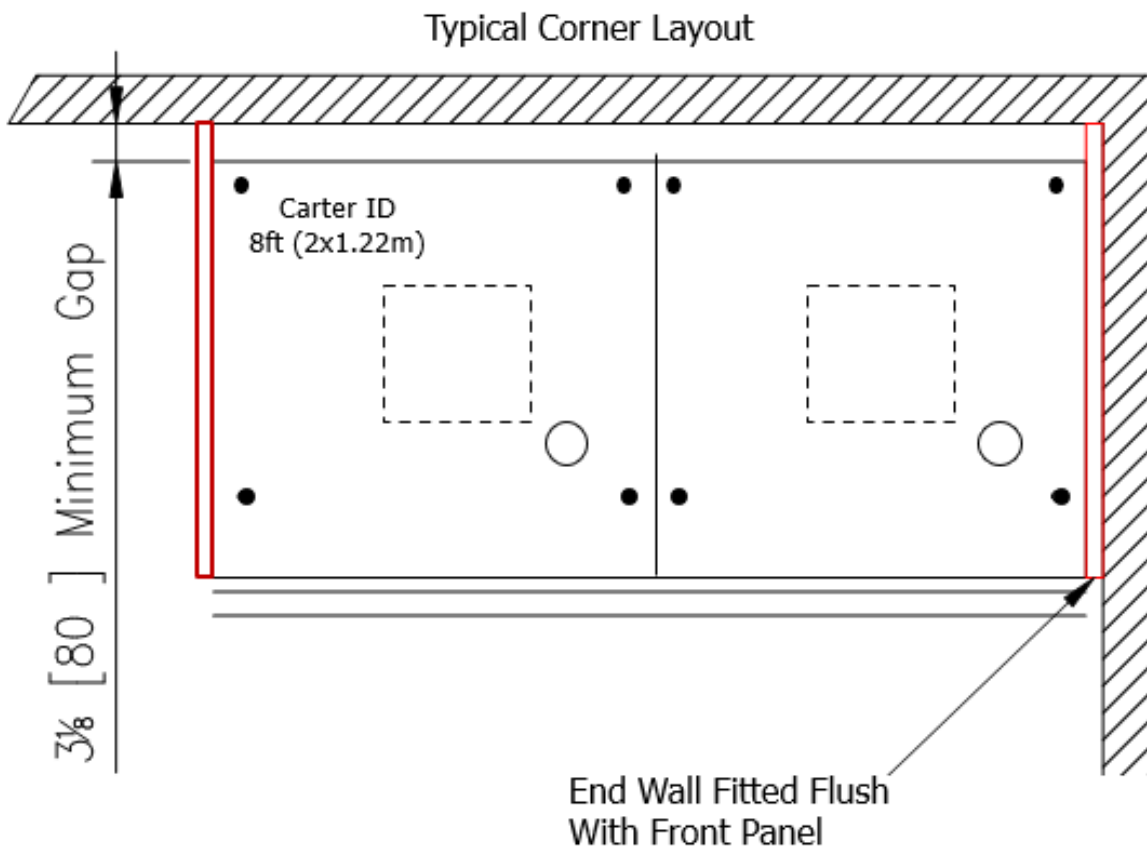

Note: Minimum Gap to rear wall dependant on use of rear duct and depth of end wall

Drawing Measurements
Inches (Metric Millimetres)

Section 05. Cabinet Plan View Showing Condensing Unit & Electrical Control Panel Location 12ft & 8ft IDA Modules - SCA

Plan View of 12ft Case (3x 4ft (1.22m) Modulation)

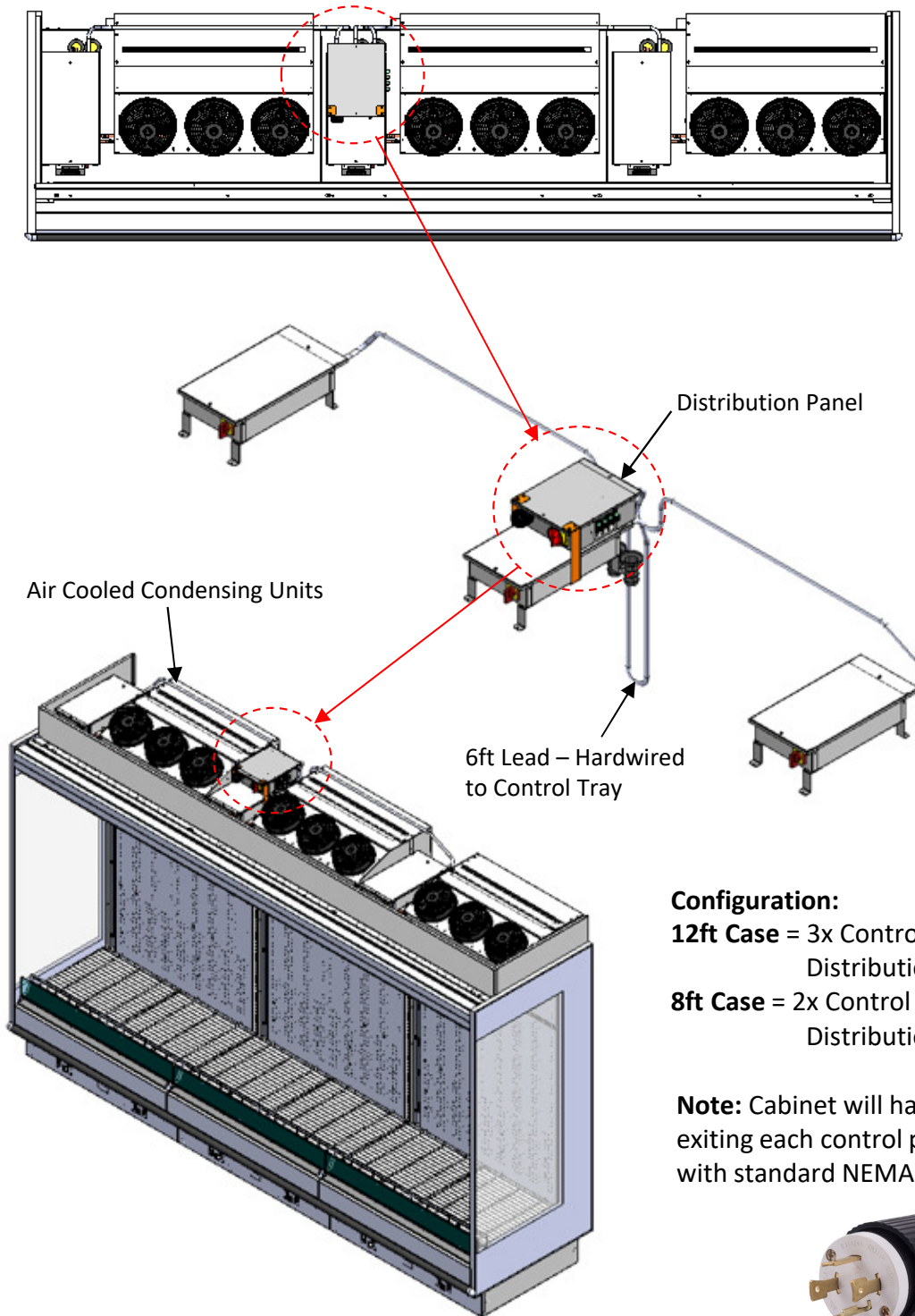

Configuration:

12ft Case = 3x Control Panels & 1x Distribution Panel

8ft Case = 2x Control Panels & 1x Distribution Panel

Note: Cabinet will have 6' lead exiting each control panel fitted with standard NEMA-L14-30P



Section 06. Electrical Schematic IDA - SCA – 4', 8' & 12' cabinet

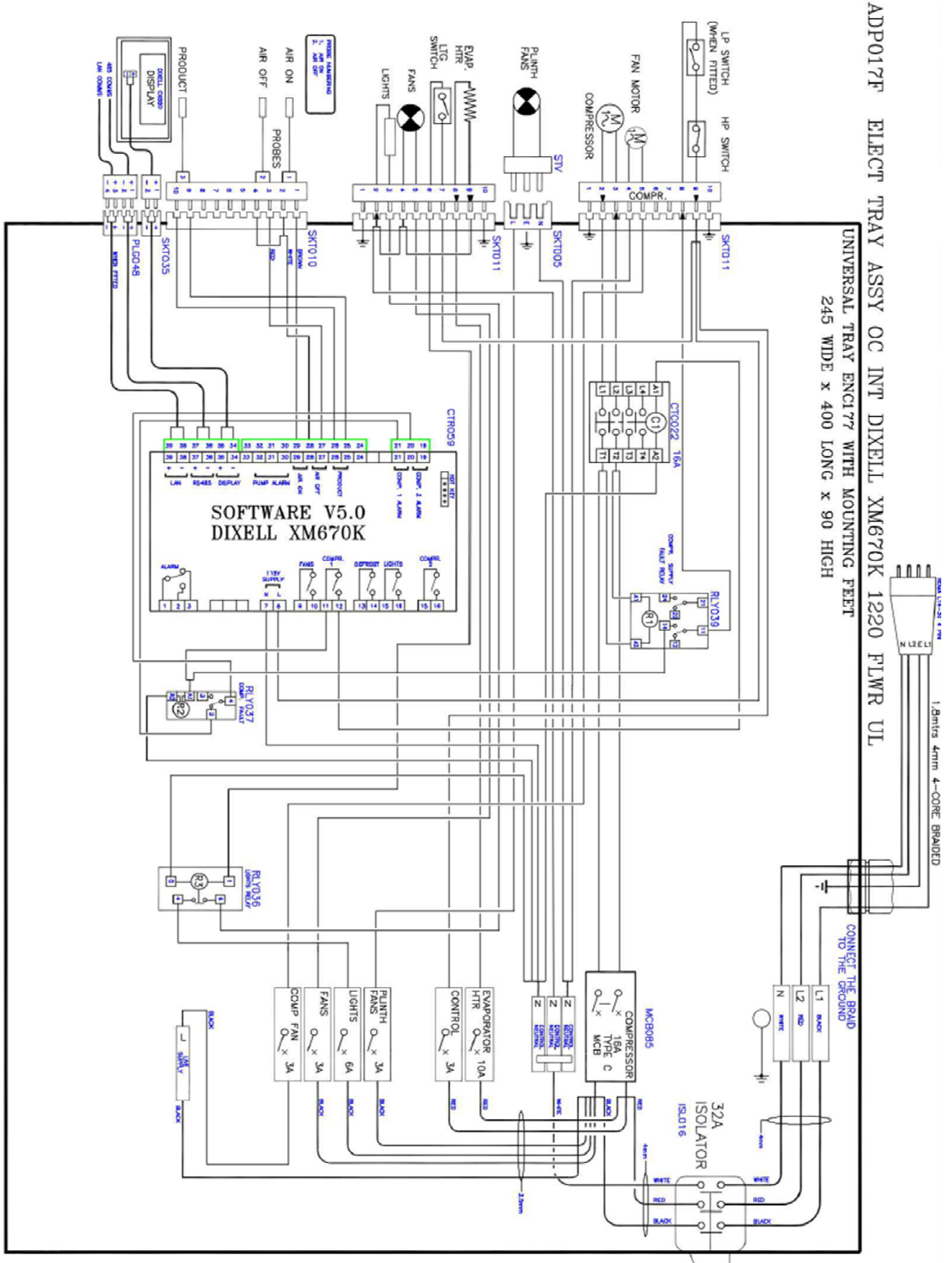

Section 06. Electrical Schematic IDA - SCA – 6' cabinet

ADP016F ELECT TRAY ASSY OC INT DIXELL XM670K 1830 FLWR UL
TRAY ENCL78 with MOUNTING FEET
350 WIDE x 400 LONG x 90 HIGH

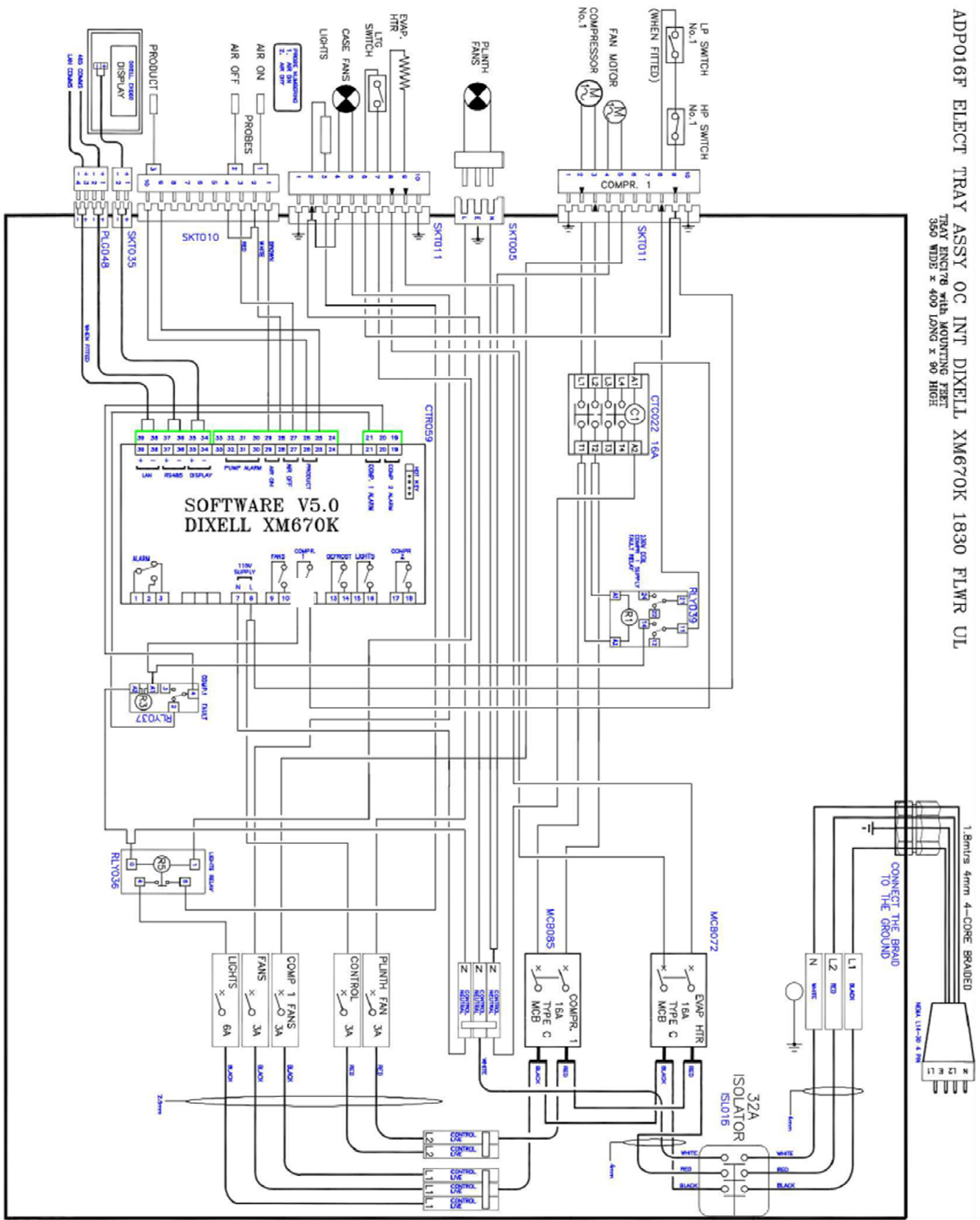

Section 06a. Electrical Distribution Panel IDA – SCA 8' & 12' cabinet

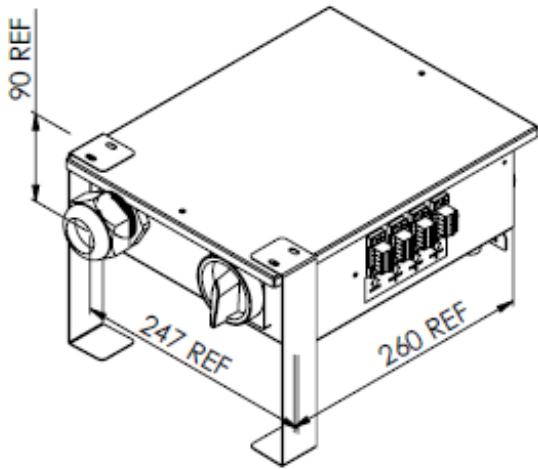

DETAIL FOR REF ONLY
BOX DIMS SHOWN ONLY
(BRACKET TO BE SUPPLIED)

1x Distribution Panel Fitted on Top of 1x Control Tray

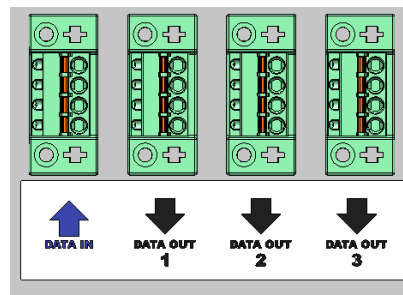
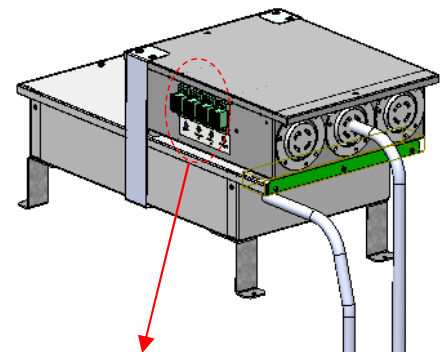
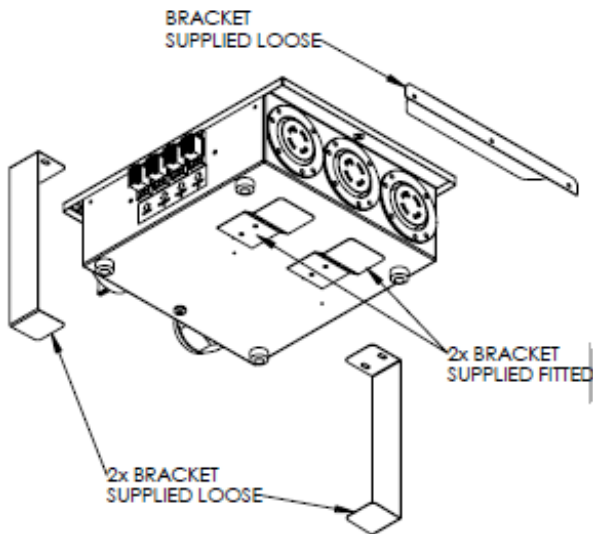
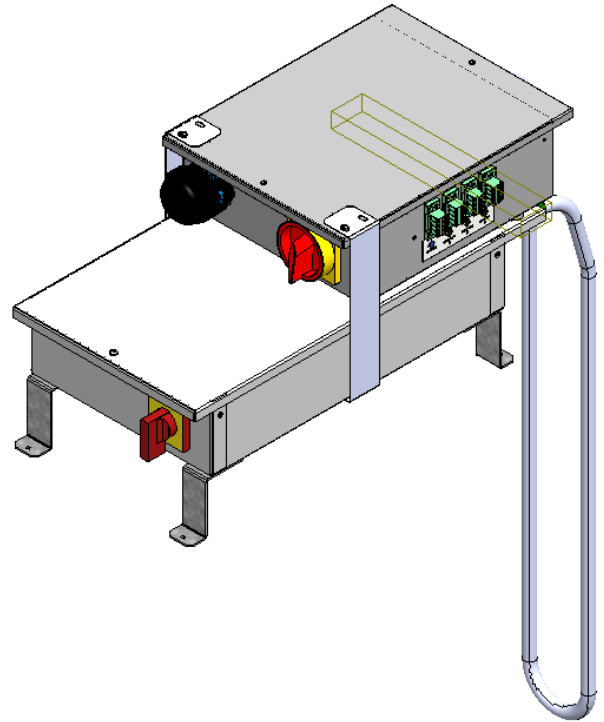

RS485 Comms Plugs

Section 07. Electrical Wiring For EVAP Fan Assembly IDA - SCA Page 12 of 17

Cabinet Loom ALM0199

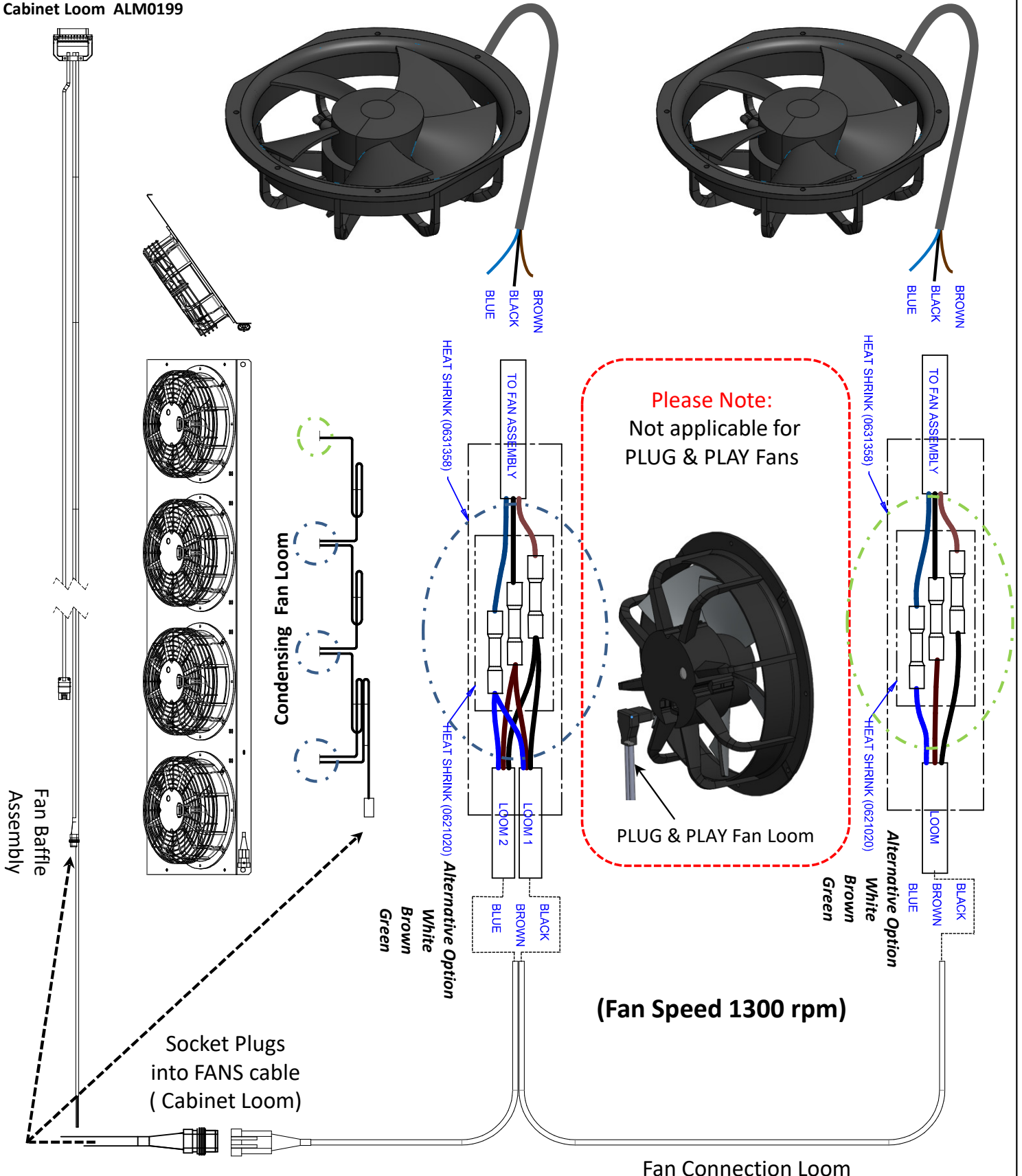

Section 08. Electrical Wiring Condensing Loom IDA - SCA

Condensing Loom Plug into Electrical Control Panel

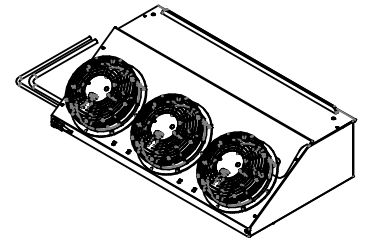
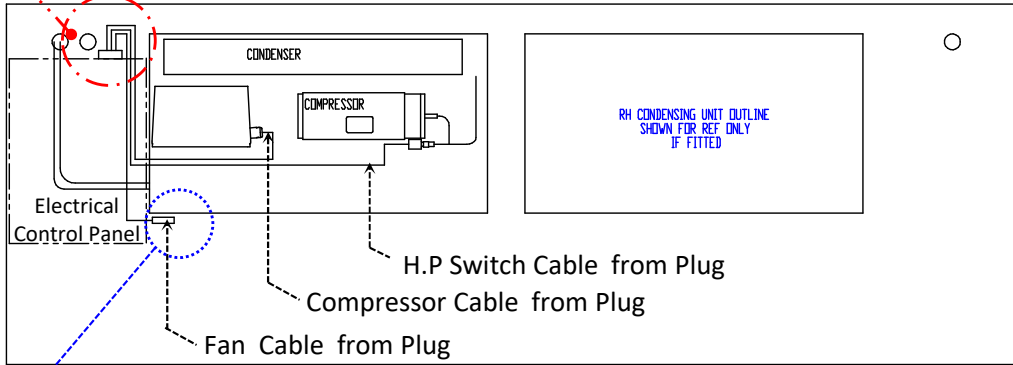

PLAN VIEW CONDENSING UNIT FITTED

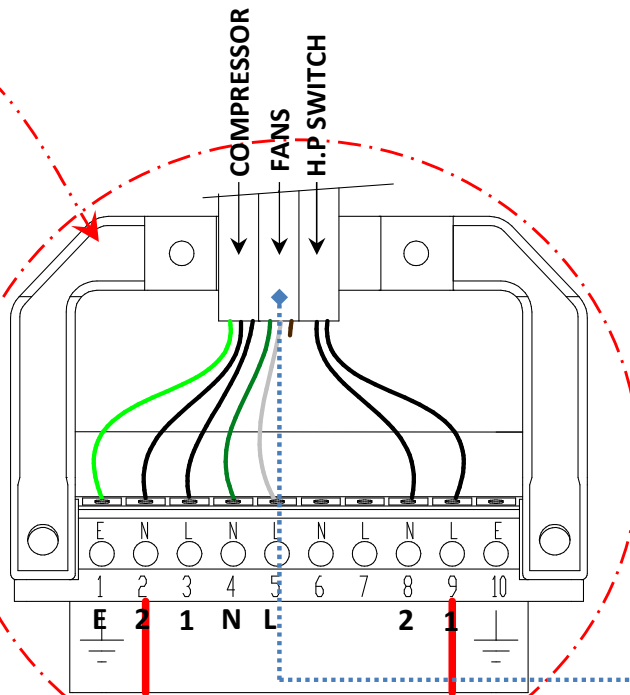

Compressor Wiring Detail (for ref only)

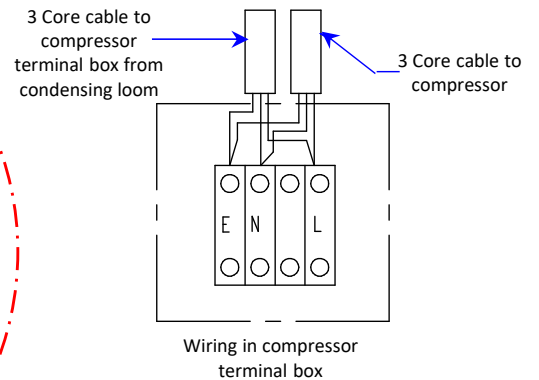

WIRING KEY

- LIVE L (1)
- NEUTRAL N (2)
- EARTH E (GREEN/YELLOW)

Wiring – Typical for LHS & RHS Condensing Loom Plug

Fan loom rework detail

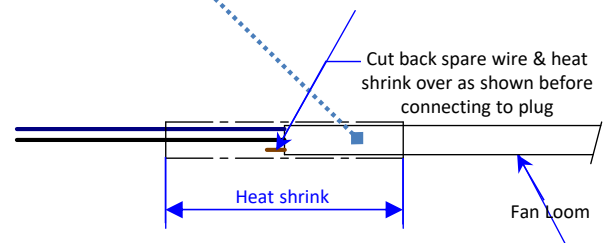

Fan lead wiring color set option 1:

White (Live), Green (Neutral) Cut back spare wire (Brown)

Fan lead wiring color set option 2:

Black (Live), Blue (Neutral) Cut back spare wire (Brown)

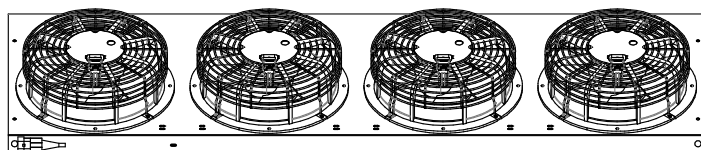

Two install options: Fan assembly connection to loom: Option 01 Plug & Play & Option 02 Wired See Section 09 of Technical Data Sheet

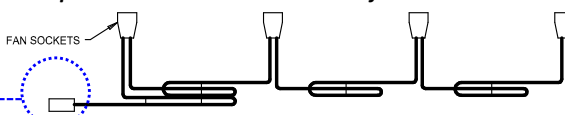

Fan Speed 1800 rpm

Section 9. Dixell Display Assembly Connections to Electrical Control Panel IDA - SCA

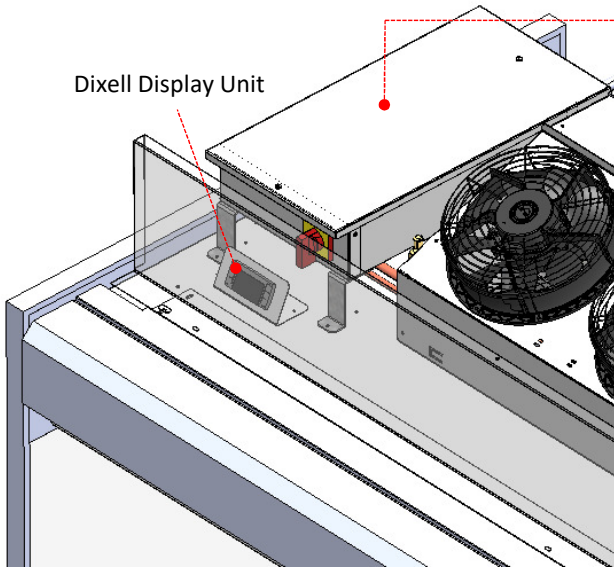

Electrical Control Panel Schematic

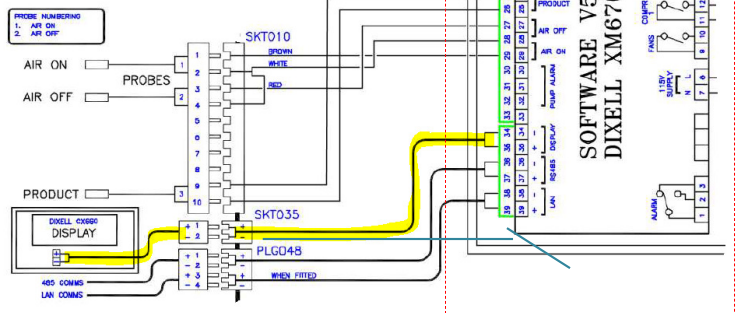

Detail View of Dixell Display Wiring Connections

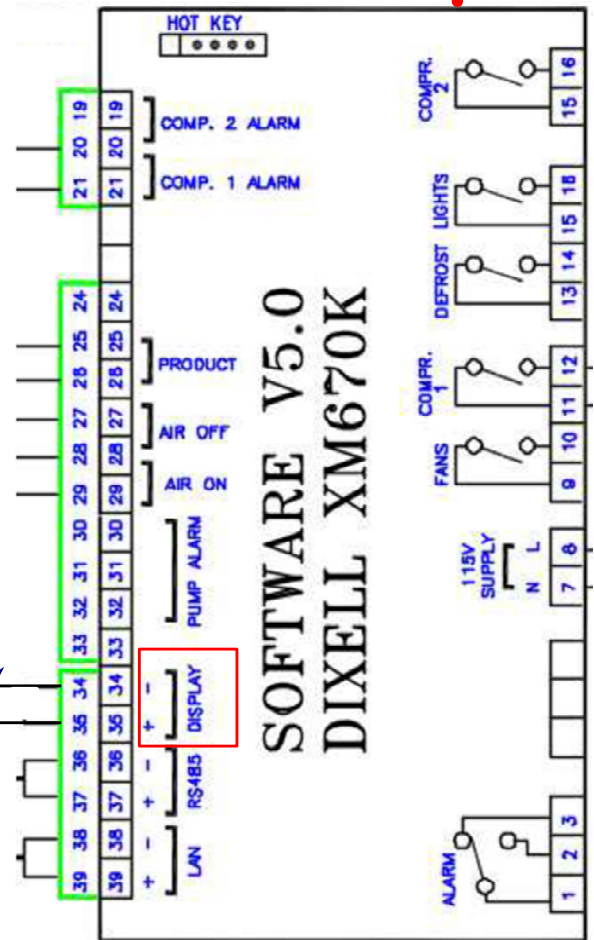

Wiring Key:

- Live (1)
- Neutral (2)

Scope of work

Rear view of display

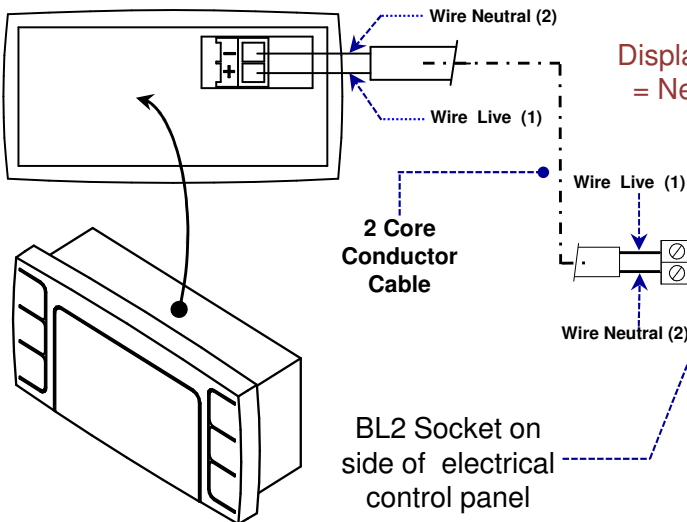

Display port 34 = Neutral (2)

Display Port 35 = Live (1)

Section 10. Kick Plate Assembly Connections to Electrical Control Panel IDA - SCA

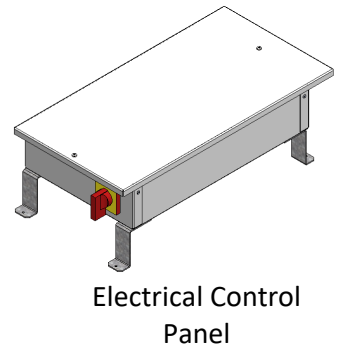
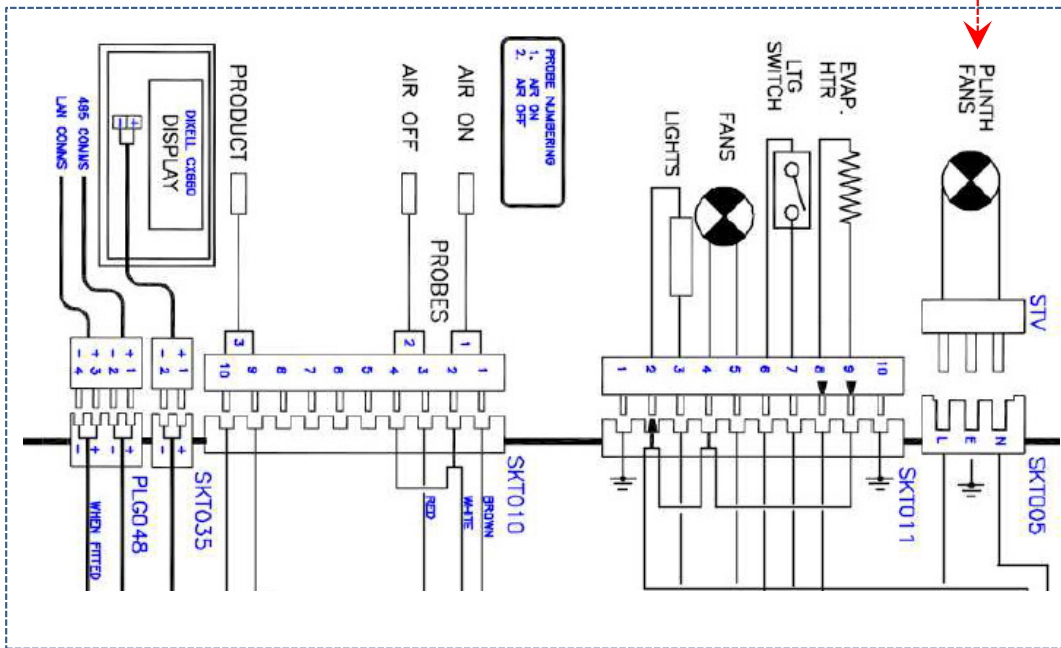

Section Plan View: Electrical Control Panel

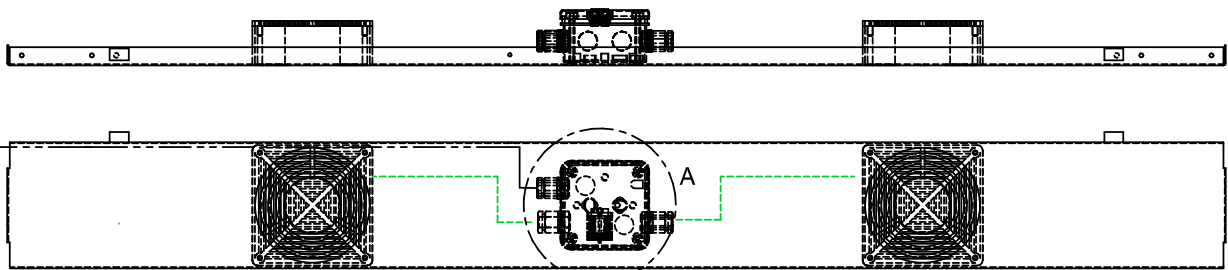
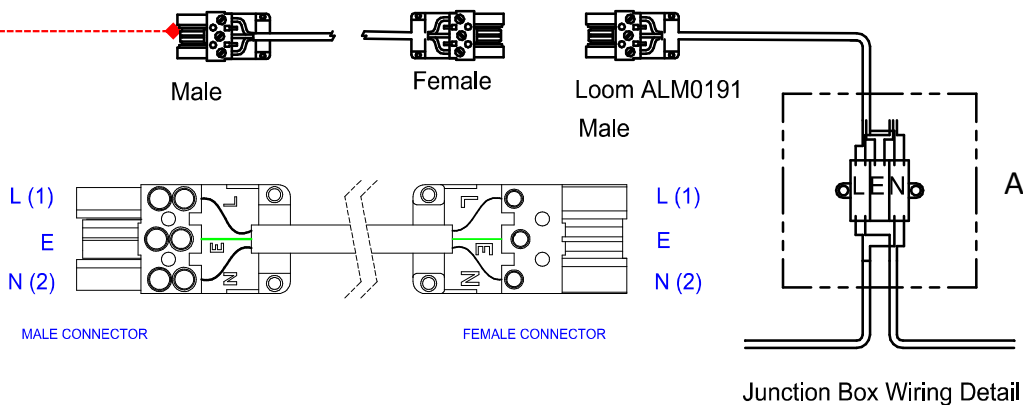

----- Fan Cable
 All Fan Cables To Be Fitted With Braided Sleeving
 _____ 3 Core Cable

Section 11. Condensate Electric Pan Heater IDA - SCA

Dimensions of Evaporative Heater for 4', 8' & 12' Cases
(Refer to Wiring Diagram)

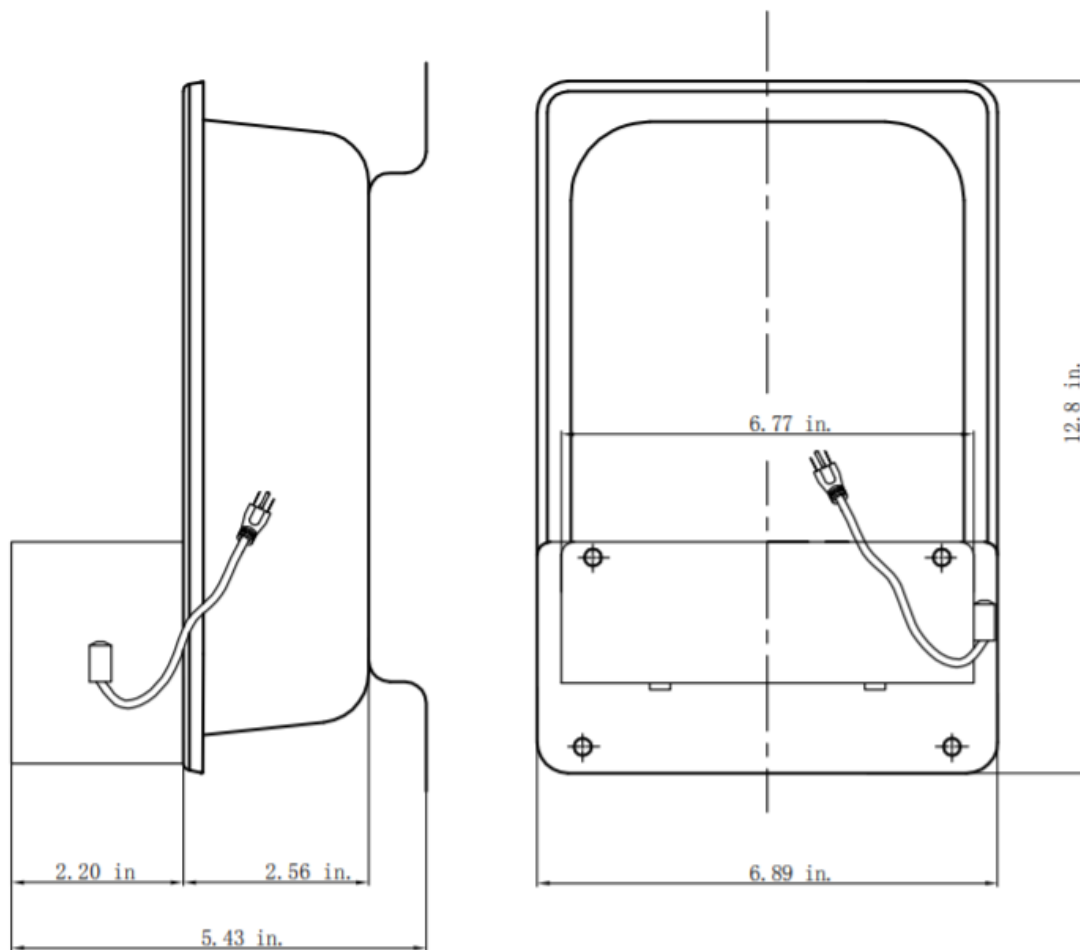

Section 12. Temperature Air 'Return' & 'Discharge' Probe Locations IDA - SCA

