



Delicatessen and Meat Serve-over Counters

The ultimate range of
modular serve-over
refrigerated cabinets

Carter Retail Equipment

The modern retailers choice in refrigerated display systems



A versatile range of serve-over counters suitable for delicatessen and meat, the Carter serve-over range offers solutions for high visibility impulse shopping. The range includes three tier shelving for bakery counters, low front self-serve counters and a serve-over complete with an upper refrigerated shelf. The refrigerated shelf can offer the capacity of a much larger counter within the foot print of an 8' (2.44mtr) or 12' (3.66mtr) counter. Carter Retail Equipment Ltd serve-over counters are available in both remote and integral versions.

All cabinets are multiplexable and are available in the following module lengths:
8' (2440mm) and 12' (3660mm)

Cabinet	Performance	Total Surface Display Area (mtr ²)	
		2.44mtr	3.6mtr
DA & DB	3M1 (-1+5°C)	2.73	4.09
JA & JB	3M1 (-1+5°C)	2.05	3.08
BA	3M1 (-1+5°C)	4.28	6.41

Carter Retail Equipment Ltd take pride in their ability to meet all individual customer requirements. All cabinets are manufactured in a purpose built UK production facility utilising latest semi-automated production flow techniques. Carter Retail Equipment Ltd refrigerated display cases are designed with an emphasis on energy efficiency and provide flexibility for the retailer with a choice of finishes and options.



Specifications

Carter Retail Equipment refrigerated display cabinets feature on the energy technology list. Further details can be found at www.eca.gov.uk

Deli Serveover with Shelf
(Integral or Remote)

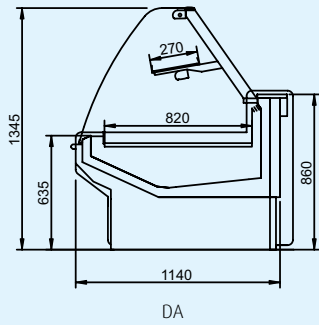

DA

Deli Serveover Low Glass
(Integral or Remote)

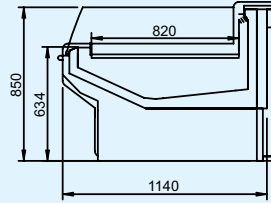

JA

Deli Serveover with Shelf
(Remote)

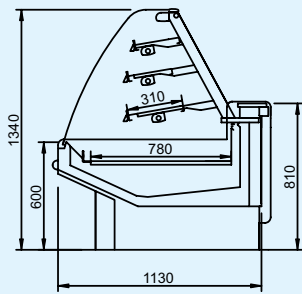

BA - 3 Shelf

Options include:

- Range of endwalls
- Rear service shelf
- Display decking
- Ticket Strip
- Humidification system
- Product dividers
- System dividers
- Various glass profiles
- Scale boards
- Queue systems
- Canopy lighting
- Cutting boards and knife racks
- Multitude of Internal and External Colours and Finishes

Profile Details

Carter Retail Equipment refrigerated display cabinets feature on the energy technology list. Further details can be found at www.eca.gov.uk