



## Roll-in Concept Cabinets

The ultimate range of modular full height refrigerated cabinets

### **Carter Retail Equipment**

The modern retailers choice in refrigerated display systems



A range of open display cabinets in a variety of heights and depths with the option of canopy or no canopy versions for the merchandising of meat, dairy and beers and wines. These are extremely versatile and flexible display cabinets suitable for both wall and island format. A number of profiling options are available including extremely low fronts which enable for example, the merchandising of wine bottles five high within a nominal height of 2000mm.

Energy efficiency is a core component of the design work Carter Retail Equipment Ltd have put into this range of display cabinets, coupled with an understanding of the modern retailer's requirements represented in a large merchandising area within a minimal footprint. The cases are available in a choice of depths and heights to suit all food retail environments.

All cabinets are multiplexable and are available in the following module lengths:

1250mm

1875mm

2500mm

3750mm

Wrap around end cases for island formats



Carter Retail Equipment Ltd take pride in their ability to meet all individual customer requirements. All cabinets are manufactured in a purpose built UK production facility utilising latest semi-automated production flow techniques. Carter Retail Equipment Ltd refrigerated display cases are designed with an emphasis on energy efficiency and provide flexibility for the retailer in choice of finishes and options.



## Specifications

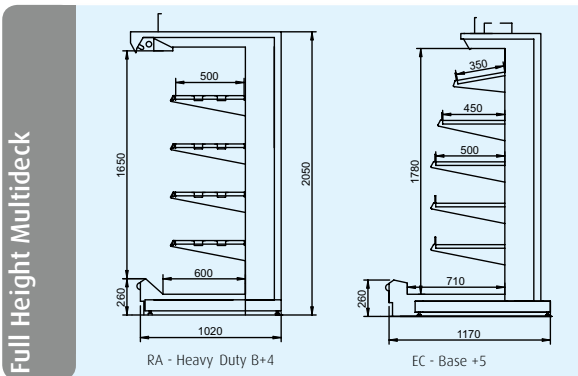

**Options include:**

- Range of endwalls
- Choice of ticket strip
- Choice of shelf risers
- Product dividers
- System dividers
- Nightblinds, Mirror Kits
- Range of Internal and External Colours and Finishes available
- Wide choice of profiling options



## Specifications

The emphasis on design of the Carter Roll-in milk is to maximise the merchandising of the product on display by minimising the amount of equipment on show from the shopper's perspective. A key feature of the design has been to omit any front panel restrictions by the use of air return grills for ease of accessibility to the product, making re-stocking of the cabinet a simple process.

The case comes complete with an upper two shelf profile. With a shelf depth of up to 600mm this offers unrivalled merchandising capacity for a roll-in milk cabinet.

RB Roll-in Milk cabinets are available in the following module lengths: 1875mm, 2500mm and 3750mm

Carter Retail Equipment refrigerated display cabinets feature on the energy technology list. Further details can be found at [www.eca.gov.uk](http://www.eca.gov.uk)

Cabinet	Performance	Total Open Display Area (mtr <sup>2</sup> )		
		1.875mtr	2.5mtr	3.75mtr
RB	3M1 (-1-+5°C)	3.38	4.5	6.75

Roll in Milk

RB - Chute Shelf + 1

Options include:

- Choice of ticket strip
- Choice of shelf risers
- Product dividers
- System dividers
- Range of Internal and External Colours and Finishes available